

PRECAST CONCRETE MANHOLE

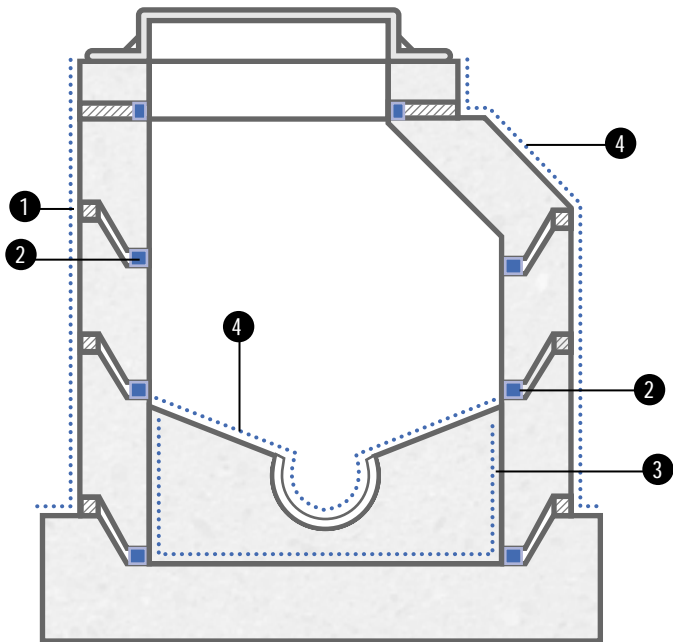

 PATCH'N PLUG

 CONCENTRATE SLURRY COAT

 CONCENTRATE DRY-PAC