

# TECHNOTE

C O M M E R C I A L



DATE 11 99

## Installation Instructions for Residential Frame Wall Construction

STYROFOAM\* brand insulation in frame wall sheathing applications

STYROFOAM\* brand Residential Sheathing, STYROFOAM DURAMATE\* brand sheathing, and STYROFOAM brand Tongue & Groove sheathing are high performance rigid foam insulations for use in residential frame wall construction. STYROFOAM DURAMATE brand sheathing is laminated with a tough plastic film to improve breakage resistance. STYROFOAM brand Residential Sheathing is laminated with a durable plastic film to reduce breakage during handling. STYROFOAM brand Tongue & Groove is unlaminated. All products are easily identified by their distinctive Blue\* color. The products are available in many sizes and R-values:

### Code Compliances

STYROFOAM brand Residential Sheathing, STYROFOAM DURAMATE brand sheathing, and STYROFOAM brand Tongue & Groove sheathing

Product	Width	Length	Thickness <sup>†</sup> (R-Value)
STYROFOAM brand Residential Sheathing	48"	8'	1/2" (R-3), 3/4" (R-4), 1" (R-5)
STYROFOAM DURAMATE brand sheathing	48"	9'	1/2" (R-3), 3/4" (R-4), 1" (R-5)
STYROFOAM brand Tongue & Groove sheathing	24"	8'	3/4" (R-3.8), 1" (R-5), 1 1/2" (R-7.5), 2" (R-10)
	48"	8'	3/4" (R-3.8), 1" (R-5), 1 1/2" (R-7.5), 2" (R-10)
	48"	9'	3/4" (R-3.8), 1" (R-5)

<sup>†</sup> All thicknesses are nominal. All products have tongue and groove long edges except 1/2" and 5/8" thicknesses which have square edges.

comply with the requirements of the following model code agencies for foam plastics:

- Building Officials and Code Administrators, Inc. (BOCA)
- Southern Building Code Congress International, Inc. (SBCCI)
- International Building Code Officials (ICBO)
- Council of American Building Officials (CABO)

### Recommended Use

STYROFOAM brand Residential Sheathing, STYROFOAM DURAMATE brand sheathing,

and STYROFOAM brand Tongue & Groove sheathing are recommended for use as nonstructural, insulated sheathings on the exterior of wood frame walls. STYROFOAM brand sheathing can be covered with a variety of exterior sidings such as aluminum, vinyl, wood, hardboard, brick or stucco. Using STYROFOAM brand sheathing on homes lowers utility bills by reducing heat loss through the walls in winter and reducing heat gain in summer. Since wood framing makes up 25% of the wall



\* The Color Blue is a Trademark of The Dow Chemical Company

\*Trademark of The Dow Chemical Company

area of a home, one-fourth of the wall is uninsulated if only cavity insulation like fiberglass batts or blown-in is used. STYROFOAM brand sheathing insulates both the wood framing and the cavity. When fastened securely to the wood studs, STYROFOAM brand sheathing also performs as an excellent air barrier, thus reducing air infiltration. The high insulation value of STYROFOAM brand sheathing helps keep the wall cavity warmer, which reduces the risk of condensation in the wall during the winter. Since it is virtually unaffected by moisture STYROFOAM brand sheathing acts as an excellent weather barrier for the exterior of the home and will not swell, delaminate, or rot.

## General Installation

STYROFOAM brand sheathing may be installed over studs on 16" or 24" centers. Boards should be butted tightly together. Forty eight inch wide sheets of STYROFOAM brand sheathing should be installed vertically with the edges located at the center of the stud. Twenty four inch wide sheets of STYROFOAM brand sheathing should be installed horizontally. Since STYROFOAM

brand sheathing is non-structural, there is no code required fastening pattern. The primary considerations are preventing blow off and making the STYROFOAM brand sheathing as "airtight" as possible to reduce air infiltration through the wall. STYROFOAM brand sheathing can be fastened with  $\frac{3}{8}$ " head roofing nails, 1" head plastic or metal cap nails, or staples. Staples should have a minimum crown of  $\frac{3}{4}$ ". All fasteners should be of sufficient length to penetrate the wood studs a minimum of  $\frac{3}{4}$ ". The figures show the general fastening patterns for both 24" and 48" wide STYROFOAM brand sheathing installed over walls with wood studs 16" o.c.

## Special Installation for Superior Air Infiltration Performance

Due to its slightly flexible and resilient nature, STYROFOAM brand sheathing has the ability to "gasket" irregularities in the wood framing, thus helping to reduce air infiltration. Forty eight inch wide sheets of STYROFOAM brand sheathing installed according to the general fastening pattern above will allow less air infiltration through the wall than rigid

## Fastening Patterns

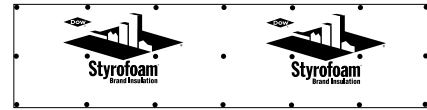

**For 24" Wide Product:  
12" o.c. at each stud**

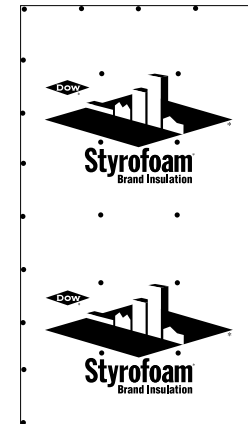

**For 48" Wide Product:  
12" o.c. along all edges  
16" o.c. in the field**

wood sheathings (fiberboard, OSB, or plywood).

For builders considering the use of a housewrap as a means of achieving additional air infiltration reductions, there is no need for the expense of a housewrap when using STYROFOAM brand sheathing. Studies have shown that air infiltration reductions superior to those of wood sheathing covered with housewrap can be achieved with STYROFOAM brand sheathing. The fastening patterns illustrated were tested

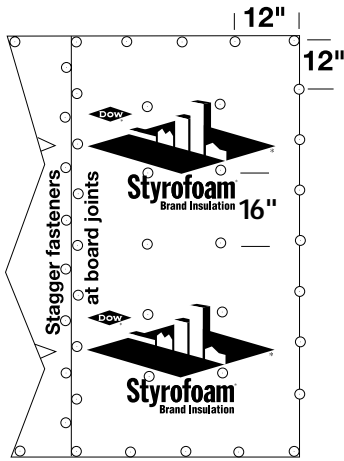

**1" and Thicker STYROFOAM brand sheathing**

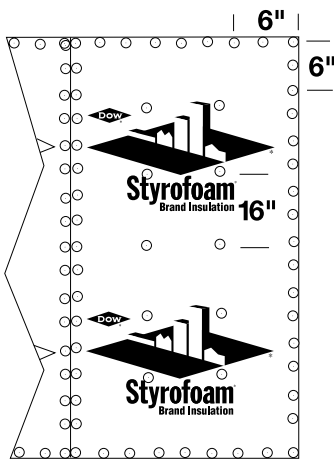

**Less than 1" Thick STYROFOAM brand sheathing**

at an independent lab and showed that the special properties of STYROFOAM brand sheathing reduce air infiltration better than wood based sheathings covered with housewrap.

For 48" wide STYROFOAM brand sheathing, center all foam joints over the center of studs and fasten the foam tightly against the studs with 1" plastic cap nails, per the appropriate diagram (minimum nail penetration of 1" into the stud). Tape those foam joints which do not fall over a stud, using a tape recommended for use with polystyrene or polyolefin-faced polystyrene foam.

### Other Considerations

With a nonstructural sheathing such as STYROFOAM brand sheathing, building codes

require the use of corner bracing. Acceptable corner bracing materials are 4' x 8' sheets of plywood/OSB, 1" x 4" wood let-in bracing, or approved metal straps. For areas of the country with special wind concerns (e.g., certain coastal areas), check with your local code official and Dow for special bracing considerations.

Some building codes require a vapor retarder of polyethylene sheeting or kraft paper batts in the wall to reduce the chance of condensation in the wall cavity. In most climates, the vapor retarder should be located directly behind the gypsum drywall. However, in hot, humid climates, where exterior humidity may be a significant concern, check with your local building code official for any special considerations.

**NOTICE:** No freedom from any patent owned by Dow or others is to be inferred. Because use conditions and applicable laws may differ from one location to another and may change with time, Customer is responsible for determining whether products and the information in this document are appropriate for Customer's use and for ensuring that Customer's workplace and disposal practices are in compliance with applicable laws and other government enactments. Dow assumes no obligation or liability for the information in this document. NO WARRANTIES ARE GIVEN; ALL IMPLIED WARRANTIES OF MERCHANTABILITY OR FITNESS FOR A PARTICULAR PURPOSE ARE EXPRESSLY EXCLUDED.

**COMBUSTIBLE:** Protect from flame and other high heat sources. For more information, consult MSDS and/or call Dow (1-800-441-4369). In an emergency, call (1-517-636-4400). Local building codes may require a protective or thermal barrier. Contact your local building inspector for more information.

For technical information, call 1-800-441-4369

The Dow Chemical Company  
200 Larkin Center  
1605 Joseph Drive  
Midland, MI 48674

